

# 5700 Series Rotary Unions for Continues Casting Machines (CCM)



**FLUIDEN 5700** Series special designed for steel making industries and rolling mill (Continuous Casting Production Lines) machines. This series rotary unions are mainly used in water service in CCM machines. The specially designed seals are withstanding with various operating conditions, such as high temperature at low rotation speed with low friction and wear.



### Special Design Features

- Self-supported rotary union
- Available in both Mono flow & Duo flow design
- Brass housing and elbow
- Corrosion resist stainless steel rotor
- In the shaft mounted design
- Widely spaced composite bearings
- Specially designed mechanical seals to sustain high pressure changes with minimum friction and wear for prolong service life
- Available in both US and metric standards
- Easy installation & repairable

#### Technical Data

- Max. Water Pressure            10 bar ( 150 psi )
- Max. Temperature            85°C ( 185° F )
- Max. Rotor Speed            250 rpm

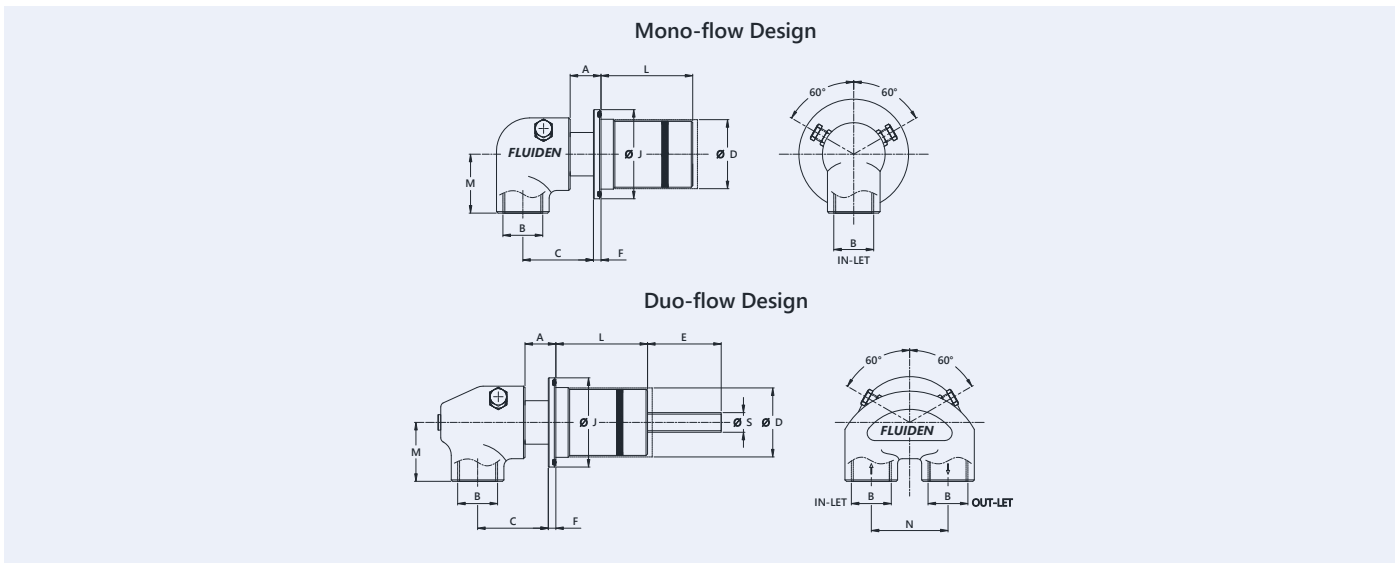

Model No.	'B' Port size	A	C	Ø D	E	F	Ø J	L	M	N	Ø S
5700-120-011	G 3/4" BSP	19	55	46.35/46.10	----	5	59	61	47	----	----
5700-120-012	3/4" NPT	19	55	46.35/46.10	----	5	59	61	47	----	----
5700-125-011	G 1" BSP	19	55	59.00/58.75	----	5	72.90	79	47	----	----
5700-125-012	1" NPT	19	55	59.00/58.75	----	5	72.90	79	47	----	----
5700-220-011	G 3/4" BSP	19	51	46.35/46.10	49	5	59	61	40	51	13.00/12.96
5700-220-021	G 3/4" BSP	19	51	59.00/58.75	63.5	5	72.90	79	40	51	19.00/18.95
5700-220-012	3/4" NPT	19	51	46.35/46.10	49	5	59	61	40	51	13.00/12.96
5700-220-022	3/4" NPT	19	51	59.00/58.75	63.5	5	72.90	79	40	51	19.00/18.95
5700-225-011	G 1" BSP	19	69	71.25/71.00	48	5	86	88	49	63.5	28.70/28.58
5700-225-012	1" NPT	19	69	71.25/71.00	48	5	86	88	49	63.5	28.70/28.58

Subject to technical & dimensional changes without prior notice.

Please do not operate at max. pressure combined with max. speed.

Customized Models are available on request.